

## INTERNAL COMBUSTION ENGINES

An Engine is a device which transforms the chemical energy of a fuel into thermal energy and uses this thermal energy to produce mechanical work. Engines normally convert thermal energy into mechanical work and therefore they are called heat engines.

Heat engines can be broadly classified into :

- i) External combustion engines ( E C Engines)
- ii) Internal combustion engines ( I C Engines )

External combustion engines are those in which combustion takes place outside the engine. For example, In steam engine or steam turbine the heat generated due to combustion of fuel and it is employed to generate high pressure steam, which is used as working fluid in a reciprocating engine or turbine. See Figure 1.

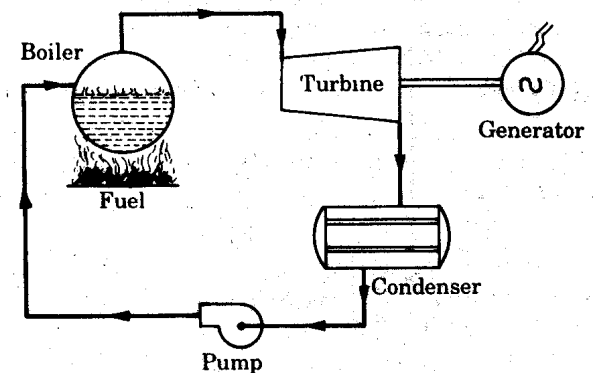

Figure 1 : External Combustion Engine

Internal combustion engines can be classified as Continuous IC engines and Intermittent IC engines.

In continuous IC engines products of combustion of the fuel enters into the prime mover as the working fluid. For example : In Open cycle gas turbine plant. Products of combustion from the combustion chamber enters through the turbine to generate the power continuously . See Figure 2.

In this case, same working fluid cannot be used again in the cycle.

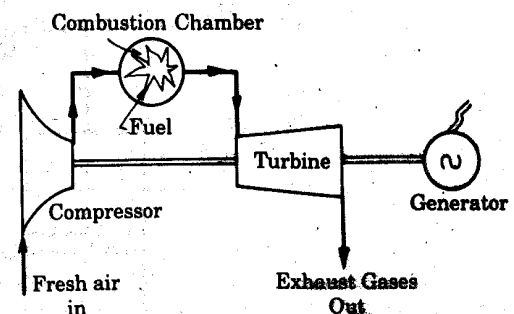
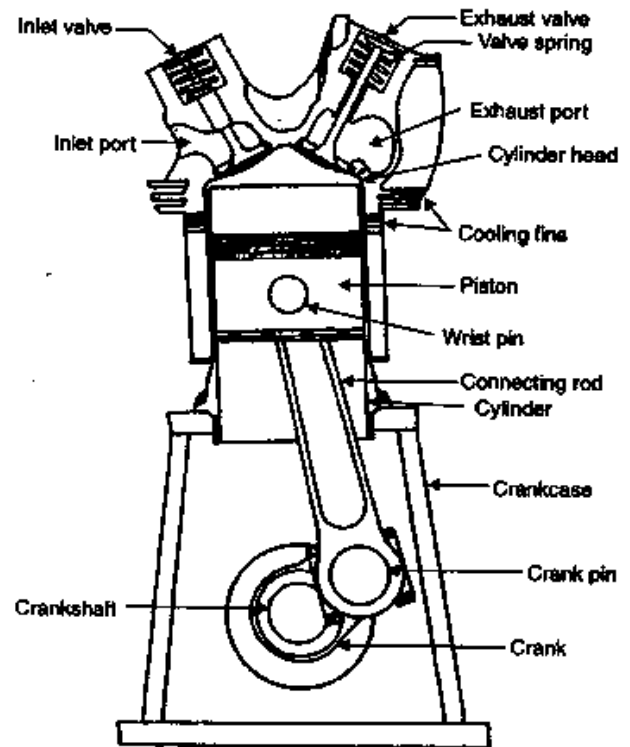

Figure 2: Continuous IC Engines

In Intermittent internal combustion engine combustion of fuel takes place inside the engine cylinder. Power is generated intermittently (only during power stroke) and flywheel is used to provide uniform output torque. Usually these engines are reciprocating engines. The reciprocating engine mechanism consists of piston which moves in a cylinder and forms a movable gas tight seal. By means of a connecting rod and a crank shaft arrangement, the reciprocating motion of piston is converted into a rotary motion of the crankshaft. They are most popular because of their use as main prime mover in commercial vehicles.



#### ADVANTAGES OF INTERNAL COMBUSTION ENGINES

1. Greater mechanical simplicity.
2. Higher power output per unit weight because of absence of auxiliary units like boiler, condenser and feed pump
3. Low initial cost
4. Higher brake thermal efficiency as only a small fraction of heat energy of the fuel is dissipated to cooling system
5. These units are compact and requires less space
6. Easy starting from cold conditions

#### DISADVANTAGES OF INTERNAL COMBUSTION ENGINES

1. I C engines cannot use solid fuels which are cheaper. Only liquid or gaseous fuel of given specification can be efficiently used. These fuels are relatively more expensive.
2. I C engines have reciprocating parts and hence balancing of them is problem and they are also susceptible to mechanical vibrations.

## CLASSIFICATION OF INTERNAL COMBUSTION ENGINES.

There are different types of IC engines that can be classified on the following basis.

1. According to thermodynamic cycle

- i) Otto cycle engine or Constant volume heat supplied cycle.
- ii) Diesel cycle engine or Constant pressure heat supplied cycle
- iii) Dual-combustion cycle engine

2. According to the fuel used:

- i) Petrol engine
- ii) Diesel engine
- iii) Gas engine

2. According to the cycle of operation:

- i) Two stroke cycle engine
- ii) Four stroke cycle engine

4. According to the method of ignition:

- i) Spark ignition (S.I) engine
- ii) Compression ignition (C I ) engine

5. According to the number of cylinders.

- i) Single cylinder engine
- ii) Multi cylinder engine

6. According to the arrangement of cylinder:

- i) Horizontal engine
- ii) Vertical engine
- iii) V-engine
- v) In-line engine
- vi) Radial engine, etc.

7. According to the method of cooling the cylinder:

- i) Air cooled engine
- ii) Water cooled engine

8. According to their applications:

- i) Stationary engine
- ii) Automobile engine
- iii) Aero engine
- iv) Locomotive engine
- v) Marine engine, etc.

## INTERNAL COMBUSTION ENGINE PARTS AND THEIR FUNCTION

1. Cylinder :- It is a container fitted with piston, where the fuel is burnt and power is produced.

2. Cylinder Head/Cylinder Cover:-

One end of the cylinder is closed by means of cylinder head. This consists of inlet valve for admitting air fuel mixture and exhaust valve for removing the products of combustion.

3. Piston:- Piston is used to reciprocate inside the cylinder. It transmits the energy to crankshaft through connecting rod.

4. Piston Rings:- These are used to maintain a pressure tight seal between the piston and cylinder walls and also to transfer the heat from the piston head to cylinder walls.

5. Connecting Rod:- One end of the connecting rod is connected to piston through piston pin while the other is connected to crank through crank pin. It transmits the reciprocating motion of piston to rotary crank.

6. Crank:- It is a lever between connecting rod and crank shaft.

7. Crank Shaft:- The function of crank shaft is to transform reciprocating motion into a rotary motion.

8. Fly wheel:- Fly wheel is a rotating mass used as an energy storing device.

9. Crank Case:- It supports and covers the cylinder and the crank shaft. It is used to store the lubricating oil.

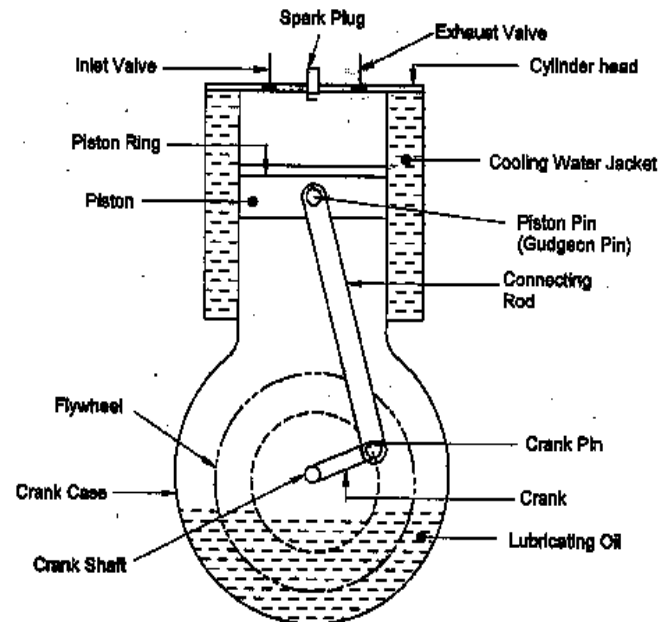
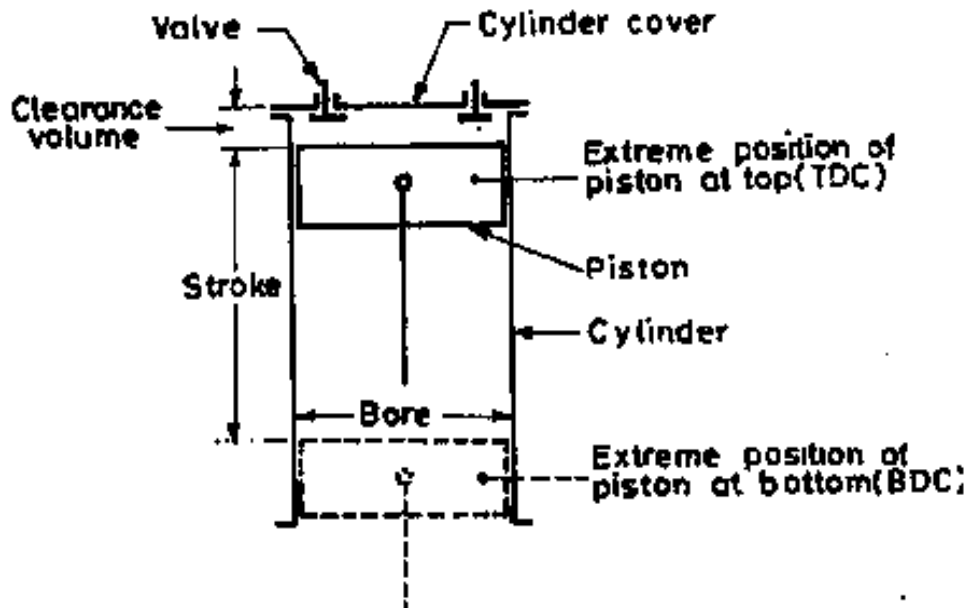

Figure: 1 I.C. Engine Parts

## IC ENGINE – TERMINOLOGY



Bore: The inside diameter of the cylinder is called the bore.

Stroke: The linear distance along the cylinder axis between the two limiting positions of the piston is called stroke.

Top Dead Centre (T.D.C) The top most position of the piston towards cover end side of the cylinder is called top dead centre. In case of horizontal engine, it is called as inner dead centre

Bottom Dead Centre (B.D.C) The lowest position of the piston towards the crank end side of the cylinder is called bottom dead centre. In case of horizontal engine, it is called outer dead centre (O.D.C).

Clearance Volume The volume contained in the cylinder above the top of the piston, when the piston is at the top dead centre is called clearance volume.

Compression ratio It is the ratio of total cylinder volume to clearance volume

Four-Stroke Petrol Engine OR Four stroke Spark Ignition Engine (S.I. engine)

The four-stroke cycle petrol engines operate on Otto (constant volume) cycle shown in Figure 3.0. Since ignition in these engines is due to a spark, they are also called spark ignition engines. The four different strokes are:

- i) Suction stroke
- ii) Compression stroke
- iii) Working or power or expansion stroke
- iv) Exhaust stroke.

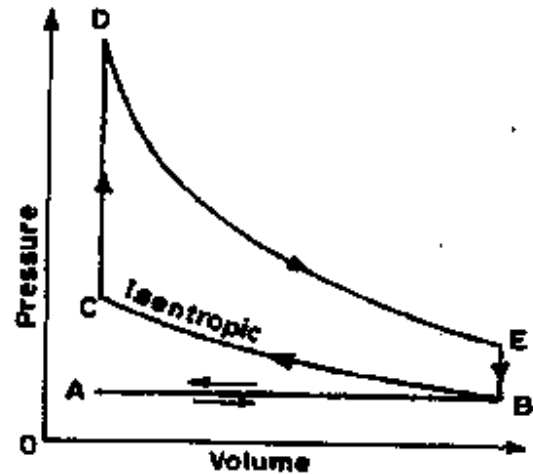
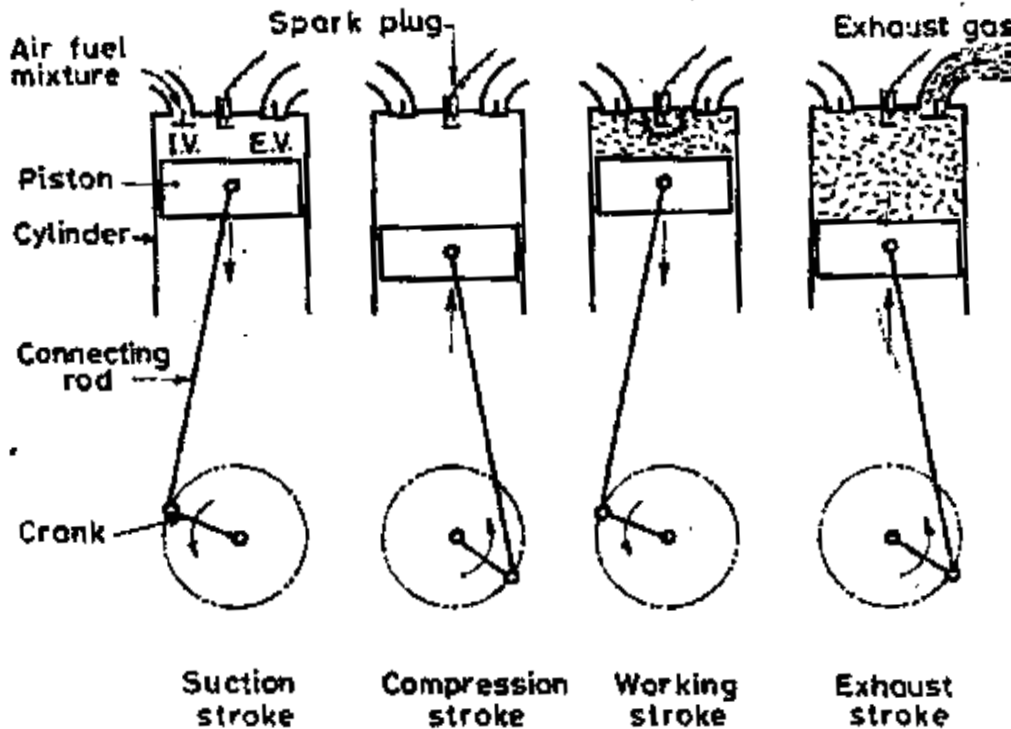

Figure: 3 Theoretical Otto Cycle

The construction and working of a four-stroke petrol engine is shown



below:

Suction Stroke : During suction stroke, the piston is moved from the top dead centre to

the bottom dead centre by the crank shaft. The crank shaft is revolved either by the momentum of the flywheel or by the electric starting motor. The inlet valve remains open and the exhaust valve is closed during this stroke. The proportionate air-petrol mixture is sucked into the cylinder due to the downward movement of the piston. This operation is represented by the line AB on the P-V diagram. (Figure 3)

Compression Stroke: During compression stroke, the piston moves from bottom dead centre to the top dead centre, thus compressing air petrol mixture. Due to compression, the pressure and temperature are increased and is shown by the line BC on the P- V diagram. Just before the end of this stroke the spark - plug initiates a spark, which ignites the mixture and combustion takes place at constant volume as shown by the line CD. Both the inlet and exhaust valves remain closed during this stroke.

Working Stroke: The expansion of hot gases exerts a pressure on the piston. Due to this pressure, the piston moves from top dead centre to bottom dead centre and thus the work is obtained in this stroke. Both the inlet and exhaust valves remain closed during this stroke. The expansion of the gas is shown by the curve DE.

Exhaust Stroke: During this stroke, the inlet valve remains closed and the exhaust valve opens. The greater part of the burnt gases escapes because of their own expansion. The drop in pressure at constant volume is represented by the line EB. The piston moves from bottom dead centre to top dead centre and pushes the remaining gases to the atmosphere. When the piston reaches the top dead centre the exhaust valve closes and cycle is completed. This stroke is represented by the line BA on the P- V diagram. The operations are repeated over and over again in running the engine. Thus a four stroke engine completes one working cycle, during this the crank rotate by two revolutions.

#### Four Stroke Diesel Engine (Four Stroke Compression Ignition Engine— C.I.Engine)

The four stroke cycle diesel engine operates on diesel cycle or constant pressure cycle. Since ignition in these engines is due to the temperature of the compressed air, they are also called compression ignition engines. The construction and working of the four stroke diesel engine is shown in fig. 4, and fig. 5 shows a theoretical diesel cycle. The four strokes are as follows:

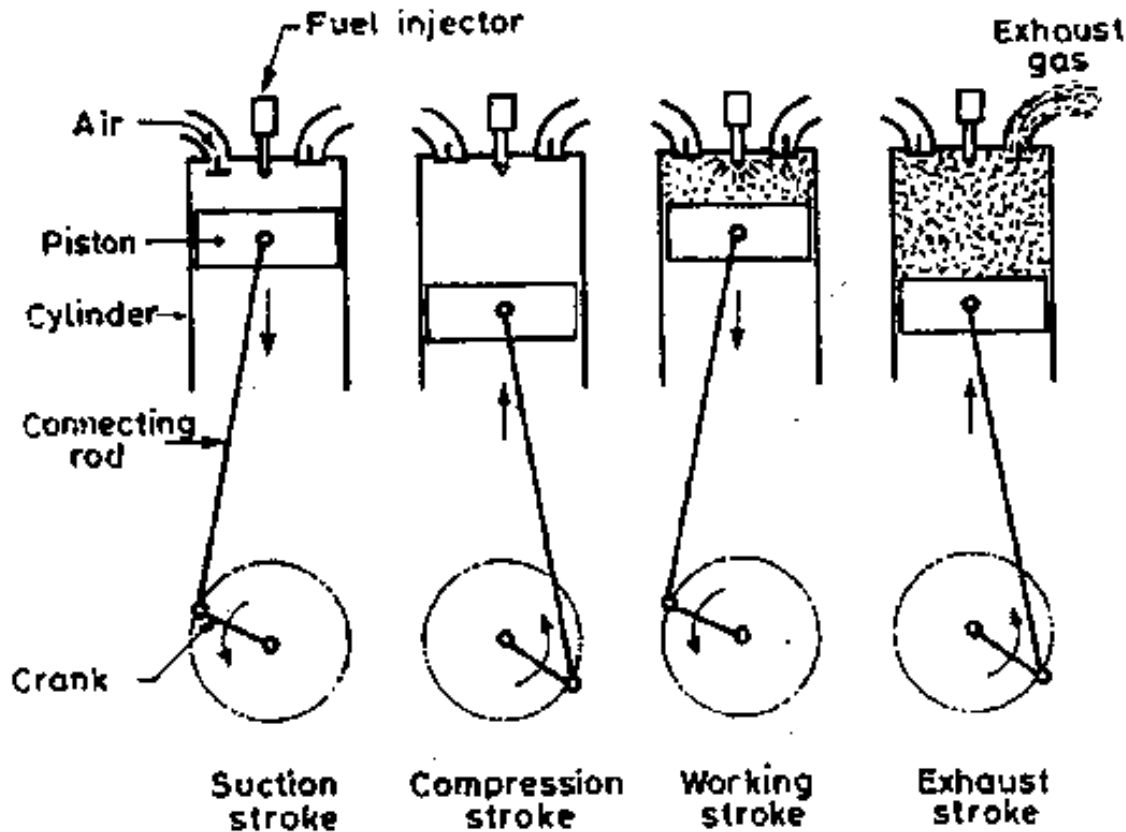

**Suction Stroke:** During suction stroke, the piston is moved from the top dead centre to the bottom dead centre by the crankshaft. The crankshaft is revolved either by the momentum of the flywheel or by the power generated by the electric starting motor. The inlet valve remains open and the exhaust valve is closed during this stroke. The air is sucked into the cylinder due to the downward movement of the piston. The line AB on the P- V diagram represents this operation.



**Compression Stroke:** The air drawn at the atmospheric pressure during suction stroke is compressed to high pressure and temperature as piston moves from the bottom dead centre to top dead centre. This operation is represented by the curve BC on the P- V diagram. Just before the end of this stroke, a metered quantity of fuel is injected into the hot compressed air in the form of fine sprays by means of fuel injector. The fuel starts burning at constant pressure shown by the line CD. At point D, fuel supply is cut off, Both the inlet and exhaust valves remain closed during this stroke

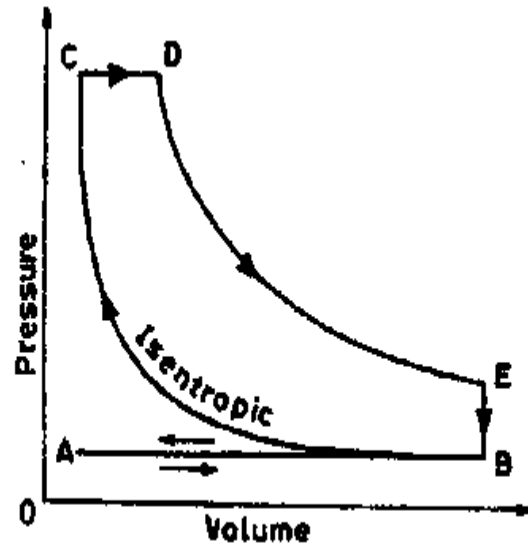

Figure: 6 Diesel Cycle (Constant Pressure cycle)

**Working Stroke:** The expansion of gases due to the heat of combustion exerts a pressure on the piston. Under this impulse, the piston moves from top dead centre to the bottom dead centre and thus work is obtained in this stroke. Both the inlet and exhaust valves remain closed during this stroke. The expansion of the gas is shown by the curve DE.

**Exhaust Stroke:** During this stroke, the inlet valve remains closed and the exhaust valve opens. The greater part of the burnt gases escapes because of their own expansion. The vertical line EB represents the drop in pressure at constant volume. The piston moves from bottom dead centre to top dead centre and pushes the remaining gases to the atmosphere. When the piston reaches the top dead centre the exhaust valve closes and the cycle is completed. The line BA on the P- V diagram represents this stroke.

## TWO STROKE CYCLE ENGINE

In two stroke cycle engines, the suction and exhaust strokes are eliminated. There are only two remaining strokes i.e., the compression stroke and power stroke and these are usually called upward stroke and downward stroke respectively. Also, instead of valves, there are inlet and exhaust ports in two stroke cycle engines. The burnt exhaust gases are forced out through the exhaust port by a fresh charge which enters the cylinder nearly at the end of the working stroke through the inlet port. The process of removing burnt exhaust gases from the engine cylinder is known as scavenging.

### Two Stroke Cycle Petrol Engine

The principle of two-stroke cycle petrol engine is shown in Figure 7. Its two strokes are described as follows:

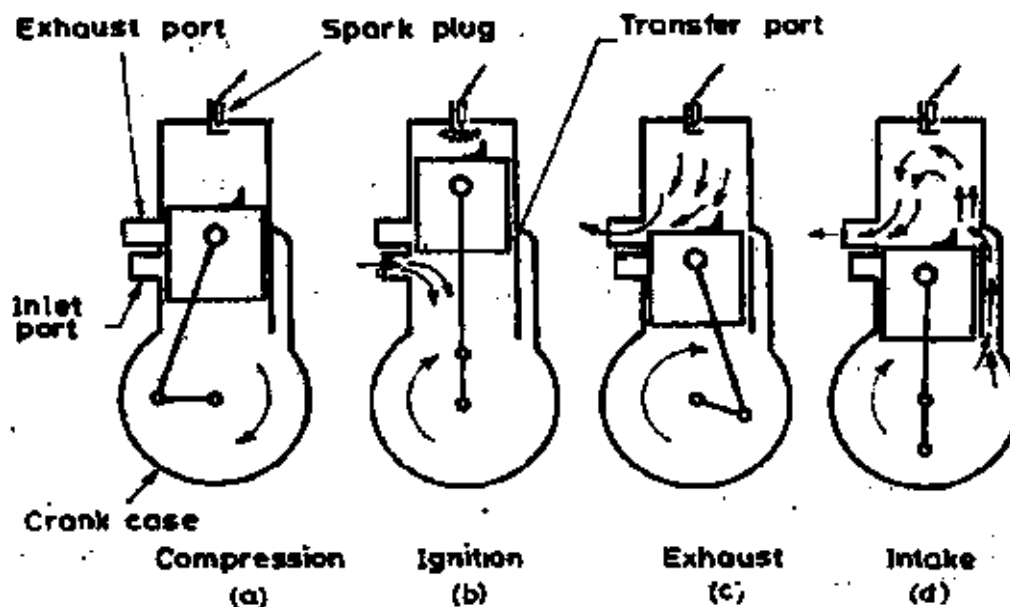

**Figure: 7 Working of Two stroke Petrol Engine**

Upward Stroke : During the upward stroke, the piston moves from bottom dead centre to top dead centre, compressing the air-petrol mixture in the cylinder. The cylinder is connected to a closed crank chamber. Due to upward movement of the piston, a partial

vacuum is created in the crankcase, and a new charge is drawn into the crank case through the uncovered inlet port. The exhaust port and transfer port are covered when the piston is at the top dead centre position as shown in Figure 7 (b). The compressed charge is ignited in the combustion chamber by a spark provided by the spark plug.

Downward Stroke: As soon as the charge is ignited, the hot gases force the piston to move downwards, rotating the crankshaft, thus doing the useful work. During this stroke the inlet port is covered by the piston and the new charge is compressed in the crank case as shown in the Figure 7(c) Further downward movement of the piston uncovers first the exhaust port and then the transfer port as shown in Figure 7 (d). The burnt gases escape through the exhaust port. As soon as the transfer port opens, the compressed charge from the crankcase flows into the cylinder. The charge is deflected upwards by the hump provided on the head of the piston and pushes out most of the exhaust gases. It may be noted that the incoming air-petrol mixture helps the removal of burnt gases from the engine cylinder. If in case these exhaust gases do not leave the cylinder, the fresh charge gets diluted and efficiency of the engine will decrease. The cycle of events is then repeated.

Self Study Topic:

- Two Stroke Cycle Diesel Engines.

## COMPARISON OF SI AND CI ENGINES

The basic differences between the SI and CI engines are given in Table 1.0

Table 1.0 Comparison of SI and CI engines

<i>SI engine</i>	<i>CI engine</i>
<ul style="list-style-type: none"> <li>• It works on Otto cycle.</li> <li>• A fuel having higher self-ignition temperature is desirable, such as petrol (gasoline).</li> <li>• Air and fuel mixture in gaseous form is inducted through the carburettor in the cylinder during the suction stroke.</li> <li>• The throttle valve of the carburettor controls the quantity of the charge. The quality of the charge remains almost fixed during normal running conditions at variable speed and load. So it is a quantity governed engine.</li> <li>• Spark is required to burn the fuel. For this, an ignition system with spark plugs is required. Because of this it is called a spark-ignition (SI) engine.</li> <li>• A compression ratio of 6 to 10.5 is employed. The upper limit is fixed by the anti-knock quality of fuel. The engine tends to knock at higher compression ratios.</li> <li>• Part load efficiency is poor, since even at part load the air/fuel ratio is not much varied. In order to improve the part load efficiency of the SI engine, the MPFI technique of fuel supply is used in modern engines.</li> <li>• The cost of the petrol is higher than that of the diesel oil.</li> <li>• Noise and vibration are less because of less engine weight.</li> <li>• The main pollutants are carbon monoxide (CO), oxides of nitrogen (NO<sub>x</sub>) and hydrocarbons (HC).</li> </ul>	<p>It works on Diesel or Dual combustion cycle.</p> <p>A fuel having lower self-ignition temperature is desirable such as diesel oil.</p> <p>Only air is introduced into the cylinder during the suction stroke and therefore the carburettor is not required. Fuel is injected at high pressure through fuel injectors direct into the combustion chamber.</p> <p>The amount of air inducted is fixed but the amount of fuel injected is varied by regulating the quantity of fuel in the pump. The air-fuel ratio is varied at varying load. So, it is a quality governed engine.</p> <p>Combustion of fuel takes place on its own without any external ignition system. Fuel burns in the presence of highly compressed air inside the engine cylinder.</p> <p>A compression ratio of 14 to 22 is employed. The upper limit of compression ratio is limited by the rapidly increasing weight of the engine. Engine tends to knock at lower compression ratios.</p> <p>Part load efficiency is good. As the load decreases, the fuel supply to the engine can also be reduced and lean mixture to the engine is then supplied.</p> <p>The cost of diesel oil is less than that of petrol. Moreover, as fuel is sold on volume basis and diesel oil has higher specific gravity, more weight is obtained in one litre.</p> <p>Noise and vibrations are more because of heavier engine components due to higher compression ratio.</p> <p>Apart from CO, NO<sub>x</sub>, and HC, soot or smoke particles are also emitted to the atmosphere.</p>

## COMPARISON OF FOUR-STROKE AND TWO-STROKE ENGINES

A comparison of four-stroke and two-stroke engines indicating their relative merits and demerits is presented in Table 2.0

**Table 2.0 Comparison of four-stroke and two stroke engines**

<i>Four-stroke engine</i>	<i>Two-stroke engine</i>
<ul style="list-style-type: none"> <li>• One power stroke is obtained in every two revolutions of the crankshaft as the cycle is completed in four-strokes of the piston or in two revolutions of the crankshaft.</li> <li>• One power stroke in two revolutions of the crankshaft makes the turning movement of the shaft non-uniform and hence a heavier flywheel is needed to rotate the shaft uniformly.</li> <li>• Power produced for the same size of the engine is less and for the same power output, the engine is larger in size, because only one power stroke is obtained in two revolutions.</li> <li>• It contains valves and valve mechanism.</li> <li>• Because of heavy weight and complicated valve mechanism, the initial cost is high.</li> <li>• Due to positive scavenging and greater time of induction, its thermal efficiency and volumetric efficiency are higher.</li> <li>• Used where high efficiency is important as in automobiles, power generation and aeroplanes.</li> <li>• Normally water-cooled, the wear and tear is therefore less. It consumes less amount of lubricant. The lubricant is placed in the crankcase. It is not mixed with the fuel.</li> </ul>	<p>One power stroke is obtained in each revolution of the crankshaft as the cycle is completed in two strokes or in one revolution of the crankshaft.</p> <p>The turning movement of the shaft is more uniform and hence a lighter flywheel is needed to rotate the shaft uniformly.</p> <p>Power produced for the same size of the engine is more and for the same power output, the engine is smaller in size, because one power stroke is obtained in every revolution.</p> <p>It has ports. Some engines are fitted with exhaust valve or reed valve.</p> <p>It is light in weight and has no valve mechanism. Its initial cost is therefore low.</p> <p>It has lower thermal efficiency and volumetric efficiency. Some of the fresh charge escapes unburnt during scavenging in petrol engines.</p> <p>Used where low cost, low weight and compactness are important as in scooters, mopeds, lawnmowers, motor cycles, etc. Two-stroke diesel engines are used in very large sizes for ship propulsion because of low weight and compactness.</p> <p>Normally air-cooled, the wear and tear is therefore more. It requires more amount of lubricant. Usually, mobil oil is mixed with fuel.</p>

CLASSIFICATION OF INTERNAL COMBUSTION ENGINES BY APPLICATION

Class	Service	Approximate range of engine power (kW)	Predominant type		
			CI or SI	No. of strokes	Method of cooling
Road vehicles	Motor cycles, scooters	0.75–37.5	SI	2,4	A
	Small passenger cars	15–75	SI	4	A, W
	Heavy passenger cars	75–375	SI	4	W
	Light commercial	37.5–150	SI, CI	4	W
	Heavy (long distance) commercial	112.5–375	CI	4	W
Off-road vehicles	Light vehicles (Factory, airport, etc.)	1.5–15	SI	2,4	A, W
	Agriculture	3–150	SI, CI	2,4	A, W
	Earth moving	37.5–750	CI	2,4	W
	Military	37.5–1875	CI	2,4	A, W
Railroad	Rail cars	150–375	CI	2,4	W
	Locomotives	375–3000	CI	2,4	W
Marine	Outboard	0.4–75	SI	2	W
	Inboard motorboats	4–750	SI, CI	4	W
	Light naval craft	30–2250	CI	2,4	W
	Ships	3750–22500	CI	2,4	W
	Ships' auxiliaries	75–750	CI	4	W
Airborne vehicles	Airplanes	50–2600	SI	4	A
	Helicopters	50–1500	SI	4	A
Home use	Lawnmowers	0.75–3	SI	2,4	A
	Snow blowers	2–4.5	SI	2,4	A
	Light tractors	2–7.5	SI	4	A
Stationary	Building service	7.5–375	CI	2,4	W
	Electric power	40–22,500	CI	2,4	W
	Gas pipe line	750–3750	SI	2,4	W
Special for racing	Vehicles and boats	75–1500	SI	4	W
Toys	Model airplanes, autos, etc.	0.01–0.4	HW	2	A

SI—Spark ignition, CI—Compression ignition, HW—hot-wire ignition carburetted mixture.

Source: Taylor, C.F.: *The Internal Combustion Engine in Theory and Practice*, Vol. 2, Table 10-1, MIT press, Cambridge, Massachusetts, 1968.

THERMODYNAMIC ANALYSIS OF I C ENGINES

According to first law of thermodynamics energy can neither be created nor be destroyed. It can only be converted from one form to other. Therefore there must be energy balance of Inputs and Outputs.

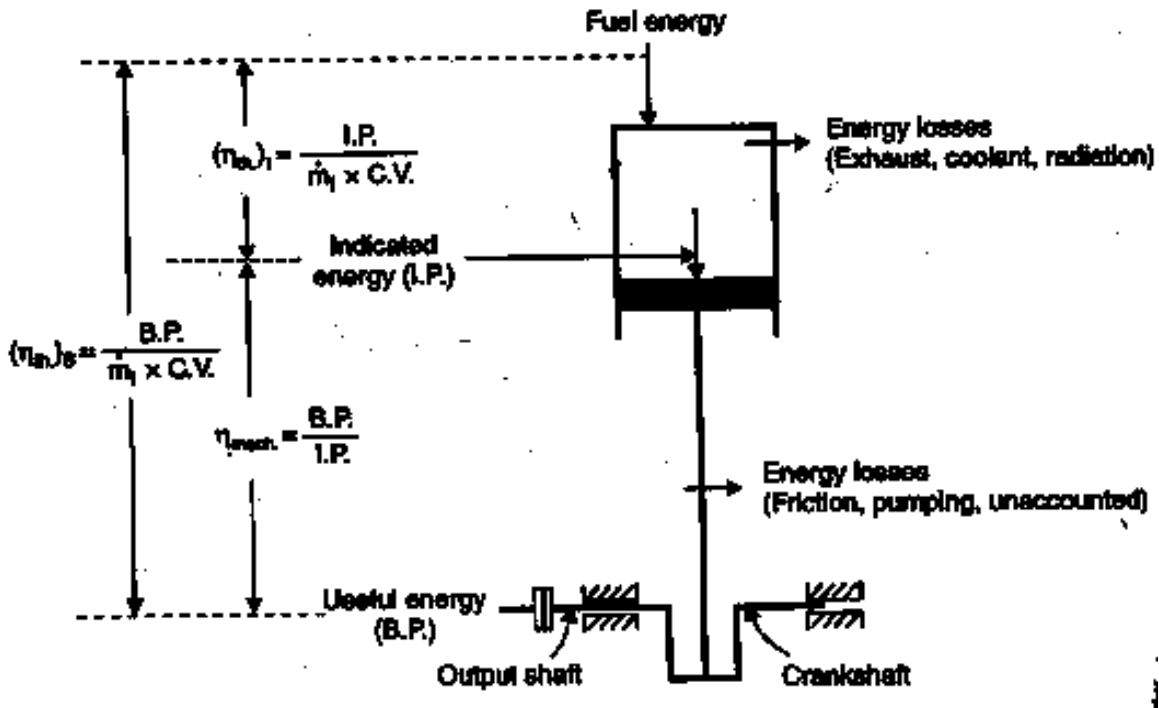

In reciprocating IC engine, fuel is fed in the combustion chamber where it burns in air, converting its chemical energy into heat. The whole of this energy cannot be utilized for driving the piston as there are losses to exhaust, to coolant and to radiation.

The remaining energy is converted into power and it is called INDICATED POWER and it is used to drive the piston. The energy represented

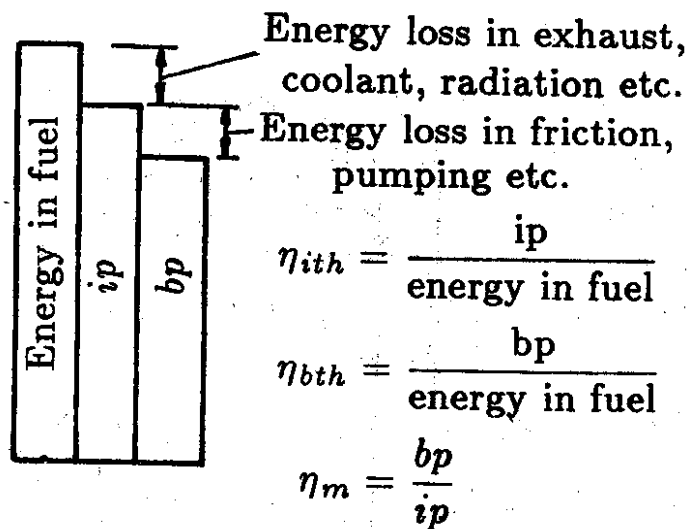

by the gas forces on the piston passes through the connecting rod to crank shaft. In this transmission there are energy losses due to bearing, friction, pumping losses etc. In addition, a part of the energy available is utilized in driving the auxiliary devices like feed pump, valve mechanism, Ignition system etc. The sum of all these losses, expressed in power units is termed as FRICTIONAL POWER. The remaining energy is the useful mechanical energy and it is termed as BRAKE POWER. In energy balance normally we do not show Frictional power, because ultimately this energy is accounted in exhaust, cooling water, radiation, etc.

The engine performance is indicated by term EFFICIENCY. Five important engine efficiencies are defined below.

### 1. Indicated thermal efficiency ( $\eta_{ITE}$ )

It is the ratio of energy in the indicated power, IP to the input fuel energy in appropriate units.

$$\eta_{ITE} = \frac{E_{iI}}{E_{if}}$$

Energy in fuel per second = mass of fuel/s x calorific value of fuel

### 2 Brake Thermal Efficiency ( $\eta_{BTE}$ )

Brake thermal efficiency is the ratio of energy in the brake power, BP, to the input fuel energy in appropriate units.

$$\eta_{BTE} = \frac{E_{iB}}{E_{if}}$$

Energy in fuel per second = Mass of fuel/s x calorific value of fuel

### 3 Mechanical Efficiency ( $\eta_{MECH}$ )

Mechanical efficiency is defined as the ratio of brake power (delivered power) to the indicated power (power provided to the piston).

$$\eta_{MECH} = \frac{B P}{I P}$$



Mechanical Efficiency can also be defined as the ratio of the brake thermal efficiency to the indicated thermal efficiency.

4 Volumetric Efficiency (  $\eta_{vol}$  )

Volumetric efficiency is an indication of breathing capacity of engine and it is defined as the ratio of air actually induced at ambient conditions to swept volume of engine.

$\eta_{vol} = \frac{M_{oc}}{M_{oc} \frac{P_1}{P} \frac{T_1}{T_2}}$
--

This can be calculated considering mass or volume. It is preferable to use mass basis as it is independent on temperature and pressure of air taken in.

5 Relative Efficiency (  $\eta_{rel}$  )

Relative efficiency or efficiency ratio is ratio of thermal efficiency of an actual cycle to that of ideal cycle.

$\eta_{rel} = \frac{A_{T_e}}{A_{S_e}}$
--

The other important parameters of engine which are also important to evaluate performance of engine are defined below.

1. Air Fuel ratio ( A/F ) or Fuel air ( F/A ) ratio:

The relative proportions of the fuel and air in engine are very important from the standpoint of combustion and efficiency of the engine. This is expressed as ratio of mass of the fuel to that of air or vice versa,

In SI engine the fuel ratio remains constant over a wide range of operation. In a CI engine at a given revolution air flow does not vary with load, it is the fuel that varies with the load. Therefore, the term Fuel air ratio is generally used instead of Air fuel ratio.

$\frac{A}{F} = \frac{M_{oc}}{M_{ofc}}$
--

## 2. Stoichiometric air fuel ratio

A mixture that contains just enough amount of air for complete combustion of fuel is called chemically correct or stoichiometric A/F ratio,

Mixture having less air than required for complete combustion is termed as rich mixture and mixture which contains air than required is termed as lean mixture. The ratio of actual air fuel ratio to stoichiometric air fuel ratio is called Equivalence ratio and is denoted by  $\phi$

$$\phi = \frac{\text{Actual air fuel ratio}}{\text{Stoichiometric air fuel ratio}}$$

Equivalence ratio  $\phi$  = means chemically correct mixture  
 $< 1$  means lean mixture  
 $> 1$  means rich mixture

## 3. Calorific value of fuel ( CV)

Calorific value of a fuel is the thermal energy released per unit quantity of fuel when the fuel is burned completely and products of combustion are cooled back to the initial temperature of the combustible mixture.

## 4. Specific fuel consumption ( SFC)

It is the fuel consumption per kW per hour. Brake specific fuel consumption (bsfc) and indicated specific fuel consumption (isfc) are the specific fuel consumption on BP and IP basis. This is important parameters for comparing the performance of two different engines or comparing the performance of the same engine at different loads.

$$\text{bsfc} = \frac{m_f}{B_p} \left[ \frac{\text{kg}}{\text{kWh}} \right]$$

$$\text{isfc} = \frac{m_f}{I_p} \left[ \frac{\text{kg}}{\text{kWh}} \right]$$

Where  $m_f$  is the mass of the fuel supplied.

### 5. Mean Effective Pressure (MEP)

MEP is the average pressure inside the cylinders of an IC engine based on calculated or measured power output. It increases as the manifold pressure increases. For any particular engine, operating at a given speed and power output, there will be specific indicated mean effective pressure, IMEP and a corresponding brake mean effective pressure BMEP. Indicated power can be shown as

$$P_i = K \frac{I}{6} \frac{L}{1} n \text{ [kW]} \quad P_b = K \frac{B}{6} \frac{L}{1} n \text{ [kW]}$$

where K - Number of cylinders, L - stroke length (m), A - area of piston (m<sup>2</sup>)

n - Number of power strokes N/2 for four stroke engine, N for 2 stroke

N - Speed in revolution per minute (RPM)

### 6. Specific power output (P<sub>s</sub>)

Specific power output of an engine is defined as the power output per unit piston area and is a measure of the engine designer's success in using the available piston area regardless of cylinder size.

$$P_s = \frac{B}{A} \frac{P}{(A)} \left[ \frac{\text{kW}}{\text{m}^2} \right] = K [BMEP] \times [Mean \text{ piston speed}]$$

Where K - constant

The specific power shown to be proportional to product of mean effective pressure and piston speed (2LN). Thus the specific power output consists of two components, viz., the force available to work and speed with which it is working. This for the same piston displacement and BMEP, an engine running at higher speed will give higher output. It is clear that the output of the engine can be increased by increasing the speed or BMEP. Increasing the speed involves increase in mechanical stresses of various components, for increasing BMEP, better heat release from the fuel is required and this will involve more thermal load on the engine.

TUTORIAL 1- REVIEW OF BASIC PRINCIPLES IN I C ENGINES.

1. A four stroke SI engine develops 37.5 kW at 85% mechanical efficiency. The SFC is 0.385 kg/kWh. The air fuel ratio is 15. Take CV of the fuel as 42 MJ/kg. find IP and FP,

$\eta_{I/T/E}$ ,  $\eta_{B/T/E}$ , Fuel consumption and air consumption per hour.

2. The following observations were obtained during a trial on four stroke diesel engine  
Cylinder Diameter-20 cm, Stroke of the piston-40 cm, crank shaft speed - 400 rpm,  
Brake load - 80 kg, Brake drum diameter - 2m, IMEP - 8 bar, Diesel oil consumption -  
1 liter/min, Specific gravity of diesel - 0.78, CV of the fuel - 44000 kJ/kg. Find IP, FP, BP

$\eta_{I/T/E}$ ,  $\eta_{B/T/E}$ ,  $\eta_{M/E/C/H}$

3. A Person conducted a test on single cylinder two stroke petrol engine and found that mechanical and brake thermal efficiencies were 70 % and 20 %. The engine with IMEP of 10 bar and runs at 400 RPM. Consuming fuel at a rate of 4.4 kg/hour. Given that calorific value of the fuel is 44000 kJ/kg. stroke to bore ratio is 1.2. find the bore and stroke of engine.

4. Four stroke CI engine of 5 MW capacity requires 5 kW to start the engine. The fuel consumption at the full load is 2000 kg/ hour. A/F - 25 Take CV of the fuel as 42 MJ/kg. find IP,  $\eta_{I/T/E}$ ,  $\eta_{B/T/E}$ ,  $\eta_{M/E/C/H}$  and air consumption per hour.

5. The A/F ratio used in SI engine of 80 kW capacity is 15:1. Find the amount of air consumed by the engine at full load when  $\eta_{B/T/E} = 25\%$ . Also find out  $m^3$  of air and  $m^3$  of fuel required per hour if density of air  $\rho_a = 1.2 \text{ kg/m}^3$  and  $\rho_f = 3.5 \text{ kg/m}^3$  Take CV of the fuel as 42500 kJ/kg.

## AIR STANDARD CYCLES

In internal combustion engines, the conversion of heat energy into mechanical work is a complicated process. As the working fluid passes through the engine and combustion of fuel takes place, complicated chemical, thermal, and physical changes occur. Friction and heat transfer between the gases and cylinder walls in actual engines, make the analysis more complicated. To examine all these changes quantitatively and to account for all the variables, creates a very complex problem. The usual method of approach is through the use of certain theoretical approximations. The two commonly employed approximations of an actual engine in order of their increasing accuracy are

- (a) air-standard cycle
- (b) fuel-air cycle.

They give an insight into some of the important parameters that influence engine performance.

In the air-standard cycle the working fluid is assumed to be air. The values of the specific heat of air are assumed to be constant at all temperatures. This ideal cycle represents the upper limit of the performance, which an engine may theoretically attain. One step closer to the conditions existing in the actual engine is to consider the fuel-air cycle. This cycle considers the effect of variation of specific heat with temperature and the dissociation of some of the lighter molecules that occur at high temperatures.

### AIR-STANDARD CYCLE

The analysis of the air-standard cycle is based upon the following assumptions:

1. The working fluid in the engine is always an ideal gas, namely pure air with constant specific heats.
2. A fixed mass of air is taken as the working fluid throughout the entire cycle. The cycle is considered closed with the same air remaining in the cylinder to repeat the cycle. The intake and exhaust processes are not considered.
3. The combustion process is replaced by a heat transfer process from an external source.

4. The cycle is completed by heat rejection to the surrounding until the air temperature and pressure correspond to initial conditions. This is in contrast to the exhaust and intake processes in an actual engine.
5. All the processes that constitute the cycle are reversible.
6. The compression and expansion processes are reversible adiabatic.
7. The working medium does not undergo any chemical change throughout the cycle.
8. The operation of the engine is frictionless.

Because of the above simplified assumptions, the peak temperature, the pressure, the work output, and the thermal efficiency calculated by the analysis of an air-standard cycle are higher than those found in an actual engine. However, the analysis shows the relative effects of the principal variables, such as compression ratio, inlet pressure, inlet temperature, etc. on the engine performance.

In the present chapter, we shall study the following air-standard cycles

- (a) Otto cycle
- (b) Diesel cycle

### OTTO CYCLE OR CONSTANT VOLUME CYCLE

A German scientist, A. Nicolaus Otto in 1876 proposed an ideal air-standard cycle with constant volume heat addition, which formed the basis for the practical spark-ignition engines (petrol and gas engines). The cycle is shown on  $p$ — $V$  and  $T$ — $s$  diagrams in Figure 2.1(a) and Figure 2.1(b) respectively.

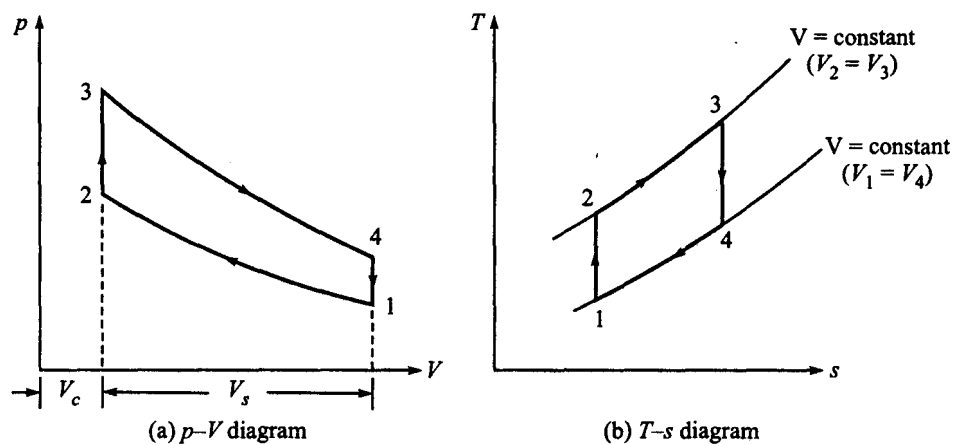

**Figure 2.1** Otto cycle.

At point 1, the piston is at the bottom dead centre (BDC) position and air is trapped inside the engine cylinder. As the piston moves upwards with valves closed, air is compressed isentropically, represented by process 1—2. At point 2, the piston reaches the top dead centre (TDC) position. Heat is supplied to the air from an outer source during the constant volume process 2—3. In an actual engine, it is equivalent to burning of fuel instant by an electric spark. At point 3, air is at its highest pressure and temperature. It is now able to push the piston from TDC to BDC and hence produces the work output. This process of expansion is an isentropic process represented by process 3-4. At the end of this expansion process, the heat is rejected at constant volume represented by process 4—1. The cycle is thus completed.

Let us summarize:

Process 1—2 is reversible adiabatic or isentropic compression. There is no heat transfer.

Process 2—3 is reversible constant volume heating.

Process 3—4 is reversible adiabatic or isentropic expansion. There is no heat transfer.

Process 4—1 is reversible constant volume heat rejection.

$V_s$  = swept volume

$V_c$  = clearance volume

$V_1$  = total cylinder volume =  $V_s + V_c$

$$\begin{aligned} \text{Compression ratio, } r &= \frac{\text{total cylinder volume}}{\text{clearance volume}} \\ &= \frac{V_s + V_c}{V_c} = \frac{V_1}{V_2} \end{aligned}$$

Thermal efficiency of any cycle,

$$\begin{aligned} \eta &= \frac{\text{work done}}{\text{heat supplied}} = \frac{\text{heat supplied} - \text{heat rejected}}{\text{heat supplied}} \\ &= 1 - \frac{\text{heat rejected}}{\text{heat supplied}} = 1 - \frac{Q_2}{Q_1} \end{aligned}$$

where

$Q_1$  = heat supplied during the cycle

$Q_2$  = heat rejected.

Let us try to express thermal efficiency of above cycle in terms of compression ratio.

The variation of compression ratio is taken from 4 to 12. These are the possible values in spark-ignition engines. Figure 2.2 shows that the thermal efficiency of the cycle increases with the increase in compression ratio. At a higher value of adiabatic exponent  $\gamma$ , the efficiency also increases.

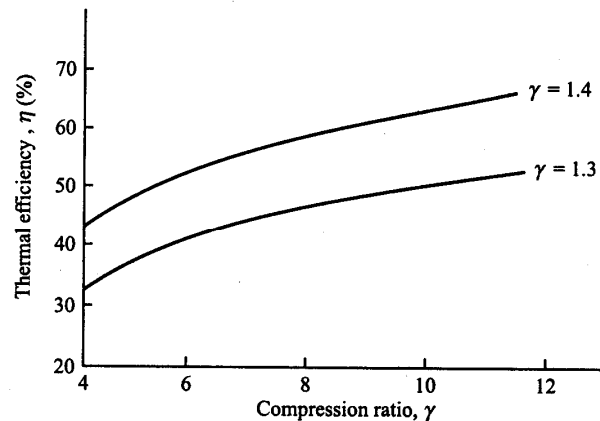

Figure 2.2 Thermal efficiency vs. compression ratio for different values of the adiabatic exponent  $\gamma$ .



## DIESEL CYCLE OR CONSTANT PRESSURE CYCLE

Rudolf Diesel in 1892 introduced this cycle. It is a theoretical cycle for slow speed compression ignition Diesel engine. In this cycle, heat is added at constant pressure and rejected at constant volume. The compression and expansion processes are isentropic. The  $p$ - $V$  and  $T$ - $s$  diagrams are shown in Figure 2.4(a) and Figure 2.4(b) respectively.

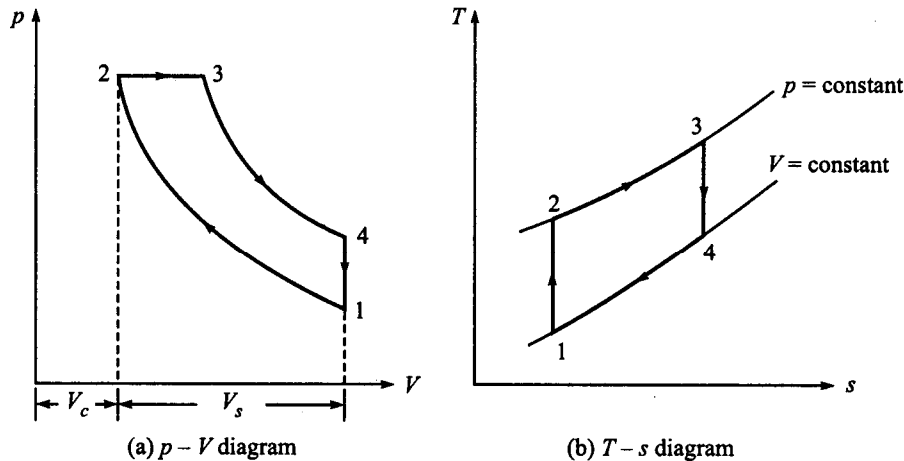

Figure 2.4 Diesel cycle.

Let us summarize:

Process 1—2 is isentropic compression. There is no heat transfer.

Process 2—3 is reversible constant pressure process. Heat is supplied during this process.

Process 3—4 is isentropic expansion. There is no heat transfer.

Process 4—1 is reversible constant volume process. Heat is rejected during this process.

Heat supplied,

$$Q_1 = mc_p(T_3 - T_2)$$

Heat rejected,

$$Q_2 = mc_v(T_4 - T_1)$$

Thermal efficiency,

$$\begin{aligned} \eta &= 1 - \frac{Q_2}{Q_1} \\ &= 1 - \frac{mc_v(T_4 - T_1)}{mc_p(T_3 - T_2)} \\ &= 1 - \frac{1}{\gamma} \left( \frac{T_4 - T_1}{T_3 - T_2} \right) \end{aligned}$$

Let us define two ratios that are useful in analysis of the Diesel cycle:

1. Compression ratio, ( $r$ ) - It is the ratio of the total cylinder volume to the clearance volume,  $r = \frac{V_1}{V_2}$

2. Cut-off ratio, ( $\beta$ ) . At point 3, the heat supplied (i.e. the fuel supply in an actual engine) is cut-off. The ratio of the volume at the point of cut-off to the clearance volume or the volume from where the heat supplied begins is called the cut-off ratio, i.e.

$$\beta = \frac{V_1}{V_2}$$

Let us now try to express thermal efficiency of above cycle in terms of compression ratio and cut off ratio.

## TUTORIAL 2 – AIR STANDARD CYCLES

### BASIC PROBLEMS ON OTTO CYCLE

1. Gas engine working on Otto cycle has a cylinder bore of 200 mm and a stroke length of 250mm. The clearance volume is 1579 cm<sup>3</sup>. The pressure and temperature at the beginning of compression are 1 bar and 27 deg C. Max. Temperature of the cycle is 1400 deg C. Determine the pressure and temperature at salient points, ASE, WD and MEP ( for air take  $C_v=0.718$  KJ/Kg. K.  $R = 0.287$  KJ/Kg K also calculate the ideal power developed by engine if the number of working cycle per minute is 500. (Answer: ASE - 51.16%, WD - 4.26 KJ, MEP- 5.424 Bar Power - 35.5 kW)
  
2. A petrol engine is supplied with fuel having a calorific value of 42000 KJ/kg. The pressure in cylinder at 5% and 75% of compression stroke are 1.2 bar and 48 bar. Assume compression follows law find the compression ratio of engine, if the relative efficiency compared to ASE is 60%. Calculate the specific fuel consumption is kg/kWh. (Answer: 0.241 kg/kWh)
  
3. An engine working on Otto cycle has a volume of 0.45 m<sup>3</sup>. pressure 1 bar and temperature of 30 deg C at the beginning of compression stroke. At the end of the compression stroke the pressure is 11 bar , 210 KJ of heat is added at constant volume . Determine the pressure temperature and volume at the salient points in cycle. Percentage clearance, Efficiency, Net work per cycle . MEP, Ideal power developed if the number of working cycles per minute is 210 . assume cycle is reversible.

### BASIC PROBLEMS ON DIESEL CYCLE

4. In an air standard Diesel cycle, compression ration is 16, cylinder bore is 200mm and stroke is 300 mm. compression begins at 1bar and 27 deg C. The cut off takes place at 8% of the stroke , Determine
  - i) Pressure, temperature and volume at all salient points, ii) Cut off ratio , iii) WD/cycle
  - iv) ASE , v) MEP, ( Answer Pressure - 2.2, WD 0 7.792 kJ, 60.4%, 8.21 bar)
  
5. In an engine working on Diesel cycle , air fuel ratio is 30:1. The temperature of air at the beginning of compression is 27 deg C. compression ratio is 16:1. What is ideal efficiency of engine based on ASE, CV of the fuel is 42000 kJ/kg ( Answer - 58.9%)

## FUEL AIR CYCLES

The theoretical cycle based on actual properties of the cylinder gas is called FUEL AIR Approximation. It provides a rough idea for comparison with actual performance. The Air standard cycle gives an estimate of engine performance which is much greater than actual performance. For example : Actual indicated thermal efficiency of a petrol engine of say 7:1 Compression ratio is in order of 15 % where as Air standard efficiency is in order of 54%. Main reason of divergence is over simplification in using the values of properties of working fluid for the cycle analysis, non – instantaneous burning and valve operations and incomplete combustion.

In air cycle approximation we have assumed that air is a perfect gas having constant specific heats. In actual engine , working fluid is not air but mixture of air ,fuel and exhaust gases. Further more, specific heats of working fluid are not constant but increase with rise in temperature and at high temperature the combustion products are subjected to dissociation.

### Assumption made for Fuel air cycle

The following assumptions are made for the analysis of Fuel air cycle

- Prior to combustion there is no chemical change in either fuel or air
- Subsequent to combustion ,the change is always in chemical equilibrium
- There is no heat exchange between the gases and the cylinder wall in any process. That is processes are adiabatic. In addition, expansion and compression process are frictionless.
- In case of reciprocating engines, it is assumed that fluid motion can be ignored inside the cylinder
- The burning takes place instantaneously at TDC ( in the case of petrol engines)
- The fuel is completely vaporized and perfectly mixed with the air ( for petrol engines)

## Factors considered for Fuel air cycles

- i). The actual composition of the cylinder gases: The cylinder gases contain fuel, air, water vapour in air and residual gas. During the operation of engine Fuel/Air ratio changes which changes relative amount of  $\text{CO}_2$ , water vapour also etc.
- ii). Variation of specific heats of gases with the temperature rise. Specific heat increase with temperature except for mono-atomic gases.
- iii). The effect of dissociation : The fuel air mixture does not completely combine chemically at high temperature (above 1600K), therefore , at equilibrium conditions of gases like  $\text{CO}_2$ ,  $\text{H}_2$ ,  $\text{O}_2$  may be present.
- iv) Variation in the number of molecules : The number of molecules present after combustion depend upon fuel air ration and upon the pressure and temperature after combustion.

## I. THE ACTUAL COMPOSITION OF THE CYLINDER GASES

The air fuel ratio changes during the engine operation. This change in air fuel ratio affects the composition of the gases before combustion as well as after combustion particularly the percentage of carbon dioxide, carbon monoxide , water vapour etc. in the exhaust gases.

In four stroke engines, fresh charges as it enters the engine cylinder comes in contact with the burnt gases left in the clearance space of the previous cycle. The amount of exhaust gases varies with speed and load on the engine. Fuel air cycle analysis takes into account the fact and the results are computed using COMBUSTION Charts. Today this types of analysis is done using computer.

## II. VARIATION OF SPECIFIC HEATS OF GASES

The specific heat of any substance is the ratio of the heat required to raise the temperature of a unit mass of substance through one degree centigrade. In case of gases temperature can be raised in two ways : either at constant pressure or at constant volume. Accordingly we have tow specific heats  $C_p$  and  $C_v$ . In general specific heats are not constant. The specific heats varies largely with temperature but not so significantly with pressure expect at high pressure.

**REASONS FOR VARIATION OF SPECIFIC HEATS OF GASES.**

The internal energy of gas is largely due to translational, rotational and vibrational energy of molecules. The energy of vibration increases rapidly with temperature and since only translational energy is measured by temperature, specific heat must increase to account for absorption of energy which increases the vibration. Thus the energy of vibration of poly atomic gas will undergo considerable change with temperature and also specific heat. The change of specific heat of monatomic gases is not considerable as molecules of monatomic gases has only translational energy.

Figure shows the effects variation of specific heats of representative gases with temperature

Note :  $K = C_p / C_v$

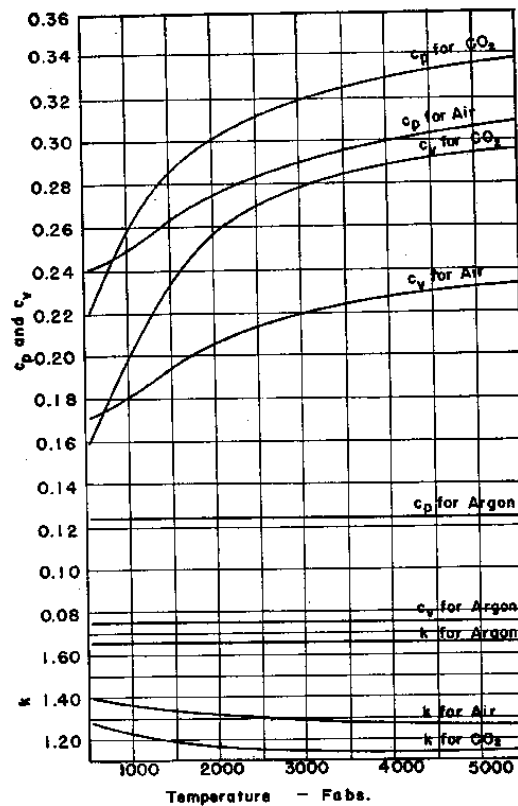
**Change of Internal Energy during a process with variable specific heat ( July 2007)**

Small change in internal energy of unit mass of a gas for small change in temperature is given by

$$\boxed{du = C_v dt} \quad \text{Now we put } C_v = b + K T \text{ and integrate between state 1 and 2.}$$

$$\boxed{u_2 - u_1 = C_{vm} (t_2 - t_1)}, \text{ where } C_{vm} \text{ is known as mean specific heat at constant volume}$$

**Home work :** Derive an expression for heat transfer during a process with variable specific heat.

**Change of Entropy during a process with variable specific heat**

Let  $p_1, v_1, T_1$  and  $p_2, v_2, T_2$  be the initial and final conditions of the gas; then the change in entropy is given by

$$\boxed{ds = \frac{dQ}{T} = \frac{pdv}{T} + \frac{C_v dt}{T} = R \frac{dv}{v} + \frac{C_v dt}{T}} \text{ put } C_v = b + K T \text{ and integrate between state 1 and 2}$$

Let us now use

$$\boxed{\left( \frac{p_1 v_1}{T_1} = \frac{p_2 v_2}{T_2} \right) = \ln \left( \frac{T_2}{T_1} \right) = \ln \left( \frac{p_2}{p_1} \right) + \ln \left( \frac{v_2}{v_1} \right)}$$

$$s_2 - s_1 = a \ln(T_2 - T_1) - (a - b) \ln\left(\frac{p_2}{p_1}\right) + K(T_2 - T_1) \text{ is the required equation.}$$

### Effect of variable specific heats on Air Standard Cycle efficiency of OTTO cycle

We already know that  $\eta = 1 - \frac{1}{r^{\gamma-1}}$  using  $R = \frac{C_p}{C_v}$

$$\frac{d\eta}{\eta} = -\left(\frac{1-\eta}{\eta}\right)(\gamma-1) \ln r \frac{dC_v}{C_v} \text{ is the required equation.}$$

Home work : Prove that variation of efficiency of DIESEL CYCLE with variation of  $C_v$   
as

$$\frac{d\eta}{\eta} = -\left(\frac{1-\eta}{\eta}\right)(\gamma-1) \left[ \frac{1}{\gamma} + \ln r - \frac{\rho^\gamma \cdot \ln \rho}{\rho^\gamma - 1} \right] \frac{dC_v}{C_v}$$



### TUTORIAL 3 – VARIATION OF SPECIFIC HEATS OF GASES

1. Petrol engine having a compression ratio, uses a fuel with a calorific value of 42 MJ/kg. The air fuel ratio is 15:1. Pressure and temperature at the start of the suction stroke is 1 bar and 57 deg C. respectively. Determine the maximum pressure in the cylinder if the index of compression is 1.3 and specific heat at constant volume is given by  $C_v = 0.678 + 0.00013 T$ , where T is in Kelvin. Compare this value when  $C_v = 0.717$  KJ/Kg. (VTU July/Aug 2005)

2. The air fuel ratio of a Diesel engine is 29:1. If the compression ratio is 16:1 and temperature at the end of the compression is 900 K. Find at what cylinder volume the combustion is complete. Express this volume as percentage of stroke. Assume that combustion begins at TDC and takes place at constant pressure. Take calorific value of the fuel as 42 MJ/kg,  $R = 0.287$  kJ/kg K and Specific heat at constant volume is given by  $C_v = 0.709 + 0.000028T$ , where T is in Kelvin. (VTU July 2007)

3. The combustion in a diesel engine is assumed to begin at IDC and to be at constant pressure. The A/F ratio is 28:1, the calorific value of the fuel is 42 MJ/kg K and specific heat of product of combustion is given by  $C_v = 0.71 + 20 \times 10^{-5} T$ , where T is in Kelvin. R for the product = 0.287 kJ/kg K. If the compression ratio is 14:1 and temperature at the end of the compression is 800 K. Find at what percentage of the stroke combustion is complete. (VTU July 2006)

4. An engine working on the OTTO cycle having compression ratio 7, uses hexane ( $C_6H_{14}$ ) as the fuel. The calorific value of the fuel is 44000 kJ/kg. The air fuel ratio of the mixture is 13:67:1. Determine 1) the percentage molecular change ii) pressure and temperature at the end of combustion with and without considering the molecular contraction. Assume  $C_v = 0.712$  kJ/kg K, compression follows the law  $PV^{1.3} = C$ . The pressure and temperature of the mixture at the beginning of compression are 1 bar and 67 deg C. (VTU Dec 06 / Jan 2007)

4. Determine the effect of percentage change in efficiency of OTTO Cycle having a compression ratio of 8. If the specific heat at constant volume increases by 1%.

5. A Diesel engine uses a compression ratio of 20. The cut off is 5 % stroke at a particular load. The value of specific heat at constant volume increase by 1%. Find the percentage change in ASE. Take  $C_v = 0.72$  kJ/kg K and R for the product = 0.287 kJ /kg K. repeat for cut off of 10 % and 15 % of the stroke. What can you deduce from this?

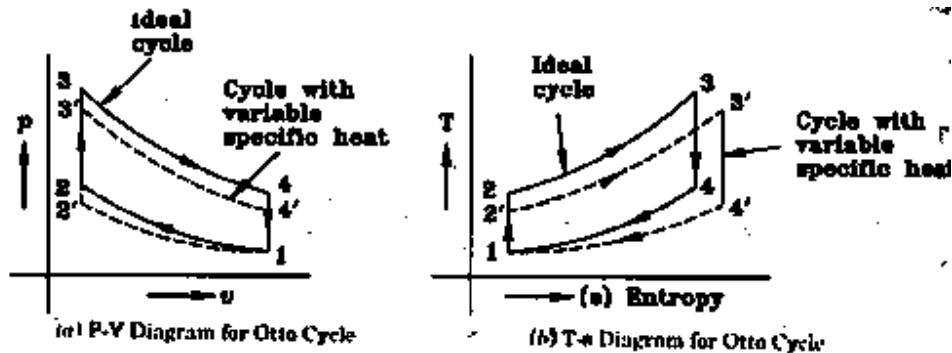
LOSS DUE TO VARIATION OF SPECIFIC HEAT IN OTTO CYCLE. ( VTU- Jan 07/ Feb 06)

The specific heats of gases increase with increase of temperature. Since the difference between  $C_p$  and  $C_v$  is constant, the value of  $\gamma$  decreases as the temperature increases. During compression stroke, if the variation of specific heats is taken into account, the final temperature and pressure would be lower than if the constant specific heats are used. With the variable specific heat the point at the end of the compression is slightly lower than 2' instead of 2.

At the end of compression pressure and temperature will be lower due to variation of  $C_v$ . Thus , it is seen that effect of variation of specific heats is to lower temperatures and pressure at point 2 and 3 and hence to deliver less work than the corresponding cycle with constant specific heats

## Home work :

Explain with the help of the following diagrams, the loss due to variation of specific heats in Diesel cycle

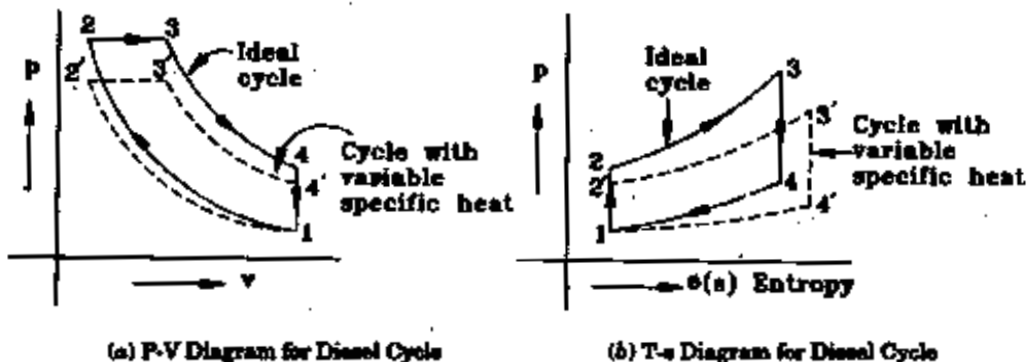

### III. LOSS DUE TO DISSOCIATION EFFECT (VTU JULY 2006)

Dissociation is a process of disintegration of combustion products at high temperature. This can also be considered as reverse process to combustion. During dissociation, heat is absorbed whereas during combustion heat is released. In I C engines, mainly dissociation of  $\text{CO}_2$  into  $\text{CO}$  and  $\text{O}_2$  occurs, whereas there is a little dissociation of  $\text{H}_2\text{O}$

Dissociation of  $\text{CO}_2$  (at 1000 deg C)



Dissociation of  $\text{H}_2\text{O}$  (at 1200 deg C)



The arrows in both directions in the above equations indicate that, limiting temperature is attained when the reaction has same rate for either direction.

Dissociation, in general, lowers the temperature and consequently pressures at the beginning of the stroke and causes a loss of power and efficiency. If the mixture is weaker, it gives temperature lower than those required for dissociation to take place. If the mixture is richer, during combustion it gives out  $\text{CO}$  and  $\text{O}_2$  both of which suppresses the dissociation of  $\text{CO}_2$ .

#### EFFECT OF DISSOCIATION ON MAX TEMPERATURE OF THE CYCLE

Figure shows the effect of dissociation on the maximum temperature for different F/A ratio. In the absence of the dissociation, max temperature occurs at chemically correct F/A ratio, with dissociation, the maximum temperature occurs when mixture is slightly 10% rich. The dissociation reduces the maximum temperature by about 300 deg C even at chemically correct air fuel ratio.

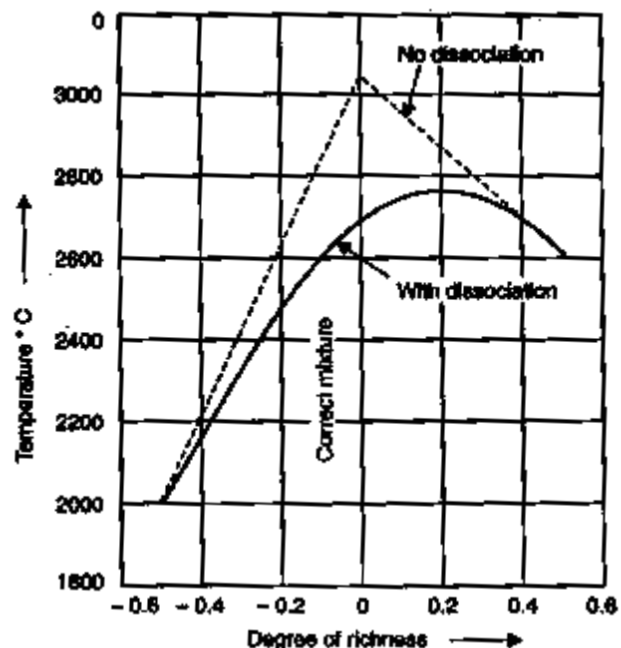

EFFECT OF DISSOCIATION ON POWER (VTU JULY 2006)

The effect of dissociation on Brake power for four stroke SI engine at constant RPM is shown in the Figure. BP of engine is maximum when the air fuel ratio is stoichiometric and there is no dissociation. The depth of shaded area between 2 BP curves shows the loss of power due to dissociation at Fuel air mixture. When the mixture is lean there is no dissociation. As the mixture becomes rich maximum temperature rises and dissociation starts.

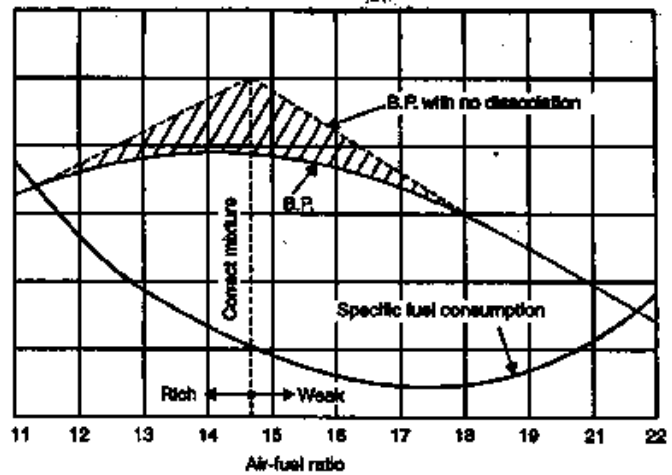

The maximum dissociation occurs at stoichiometric air fuel ratio. The dissociation starts declining at rich mixture because of increased quantity of CO in burned gases.

EFFECT OF DISSOCIATION ON OTTO CYCLE

The effect of dissociation on Otto cycle is shown in adjacent figure. Because of lower maximum temperature due to dissociation, the maximum pressure of cycle also falls and state of gas after combustion is shown by point  $3^1$  instead of 3. If there is no re-association during expansion, the expansion follows the process  $3^1-4^{11}$  but if there is some re-association, due to fall of temperature, then the expansion follows the process  $3^1-4^1$ . It is obvious from the figure, the phenomenon causes loss of power and efficiency of the engine.

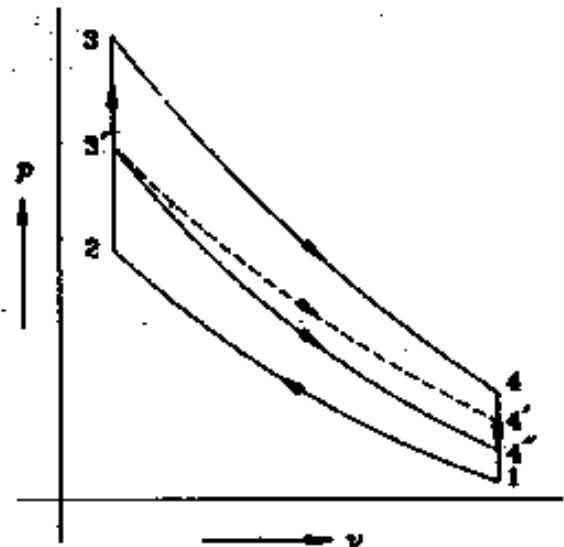

Home work :

- Why dissociation effect is not pronounced in CI Engine ?.

#### IV. VARIATION IN THE NUMBER OF MOLECULES :

The number of moles or molecules present in cylinder after combustion depends upon the A/F ratio and extent of reaction in cylinder. According to gas law,  $p\bar{V} = M\mathfrak{R}T$ , where  $\bar{V}$  molal volume, M is the number of kg moles.  $\mathfrak{R}$  is the universal gas constant. It is obvious from the equation that pressure depends on the moles present. This has direct effect on the amount of work developed by the gases in the cylinder.

### ACTUAL CYCLES

Actual cycle efficiency is much lower than Air standard efficiency due to various losses occurring in actual engine operations. They are :

1. Losses due to variation of specific heats
2. Chemical equilibrium losses or dissociation losses
3. Time losses
4. Losses due to incomplete combustion
5. Direct heat losses
6. Exhaust blow down gases
7. Pumping losses.

If we subtract losses due to variable specific heat and dissociation from the air standard cycle we get fuel air cycle analysis and if we further subtract other above losses from fuel air cycle we can very closely approximate the actual cycle.

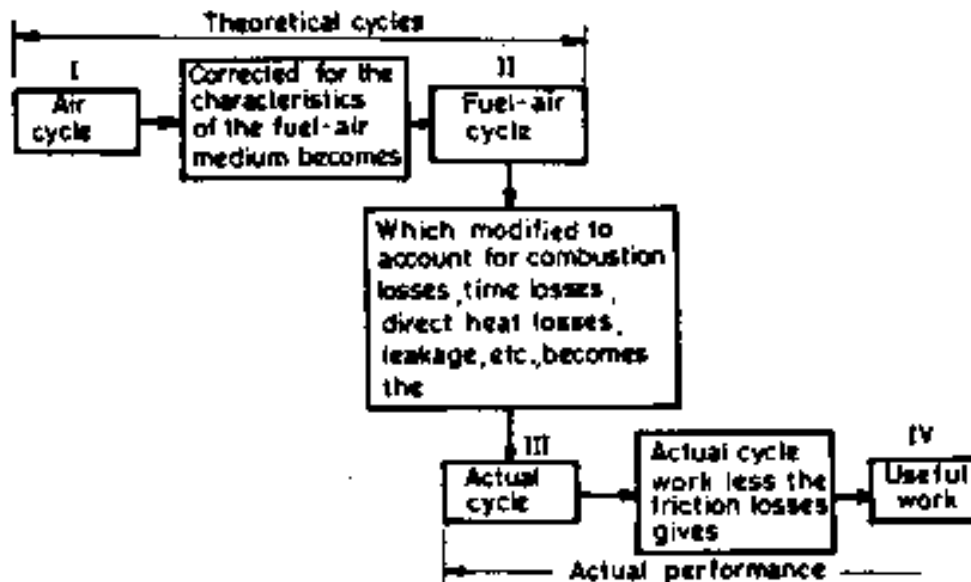

**Factors that affect the deviation of actual cycles from Theoretical cycle. ( Jan 06/ July 05)**

Actual cycle for IC engine differ from Air standard cycles in many respects as listed below

1. Working substance is not air. But mixture of air, fuel during the suction and compression and many gases during the expansion and exhaust.
2. Combustion of fuel not only adds heat but changes the chemical composition
3. Specific heat of gases changes with respect to temperature
4. The residual gases change the composition , temperature and amount of fuel charge.
5. The constant volume combustion is not possible in reality
6. Compression and expansions are not isentropic
7. There is always some heat loss due to heat transfer from hot gases.
8. There is exhaust blow down due to early opening of exhaust valve
9. There are losses due to leakages and friction

**COMPARISION OF AIR STANDARD CYCLE, FUEL AIR CYCLE AND ACTUAL CYCLE IN SI ENGINE ON THE BASIS OF OPERATION AND WORKING MEDIA. ( VTU JULY 2006)****AIR CYCLE**

- The working medium is air throughout the cycle. It is assumed to be an ideal gas with constant properties.
- The working medium does not leave the system, and performs cyclic processes.
- There are not inlet and exhaust strokes.
- The compression and expansion processes are isentropic.
- The heat addition and rejection are instantaneous at T.D.C. and B.D.C. respectively, at constant volume.

**FUEL-AIR CYCLE**

- The cylinder gases contain fuel, air, water vapour and residual gases.
- The fuel-air ratio changes during the operation of the engine which changes the relative amounts of CO water vapour etc.
- The variations in the values of specific heat and  $\gamma$  with temperature, the effects of dissociation, and the variations in the number of molecules before and after combustion are considered.

Besides taking the above factors into consideration, the following assumptions are commonly made for the operation in

- No chemical change prior to combustion.
- Ch is always in equilibrium after combustion.
- Compression and expansion processes are frictionless, adiabatic.
- Fuel completely vaporized and mixed with air.
- Burning takes place instantaneously, at constant volume, at T.D.C.

The fuel air cycle gives a very good estimate of the actual engine with regards to efficiency, power output, peak pressure, exhaust temperature etc.

### ACTUAL CYCLE

- The working substance is a mixture of air and fuel vapour, with the products of combustion left from the previous cycle.
- The working substance undergoes change in the chemical composition.
- Variation in specific heats takes place. Also the temperature and composition changes due to residual gases occur.
- The combustion is progressive rather than instantaneous.
- Heat transfer to and from the working medium to the cylinder walls take place.
- Exhaust blow down losses i.e. loss of work due to early opening of the exhaust valves take place.
- Gas leakage and fluid friction are present.

### COMBUSTION CHARTS ( VTU JULY 2007,AUGUST 2005, February 2006)

Combustion charts or Equilibrium charts are thermodynamic charts embodying characteristics of cylinder gases that are employed for computing fuel air cycles , avoiding laborious calculations. J.B. Heywood developed a new set of charts in SI units, following the approach of Newhall and Starkman. Nowadays, these charts are not much used and have been replaced by computer models. However, these charts are useful to analyze the fuel-air cycles where a limited number of calculations are required.

Two types of charts are developed for each fuel:

1. Unburned mixture charts for the properties of gases before combustion.
2. Burned mixture charts for the properties of burned gases after combustion under chemical equilibrium.

### Unburned Mixture Charts

The properties of the gases depend upon the air/fuel ratio and the residual gases in the mixture. For different operating conditions of the engine the air/fuel ratio and the amount of residual gases change, therefore an infinite number of charts would theoretically be required. However, a limited number of charts are used to cover the range of mixtures normally used in SI engines. The thermodynamic charts developed for unburned mixtures are designed specifically for application to internal combustion engine cycle processes. The thermodynamic properties of each of the fuel- air mixtures considered are represented completely by a set of two charts. The first is indeed for use in the determination of mixture temperature, pressure and volume at the beginning and end of the compression process, and the other is for the determination of the corresponding internal energy and enthalpy values.

### Burned Mixture Charts.

These charts are prepared on the basis of combustion of 1 kg of air with specific weight of fuel. The combustion product composition was considered to include H, H<sub>2</sub>, H<sub>2</sub>O, OH, CO, CO<sub>2</sub>, N, N<sub>2</sub>, O, O<sub>2</sub> and NO. Energy, enthalpy and Entropy values for each of chemical species over full range of temperatures can be obtained from these charts. In addition, the determination of equilibrium products composition requires equilibrium constants for each of dissociation reactions. Professor J B Heywood used data from JANAF thermodynamic data tables published by the Joint army Navy air force panel on Chemical thermodynamics. Each chart is a plot of internal energy versus entropy for a particular fuel and equivalence ratio. Lines of constant temperature, pressure and specific volumes are drawn on each chart. Figure 4.19 shows one these charts using Iso octane as fuel with a equivalence ration of 1.0 for illustration purpose.



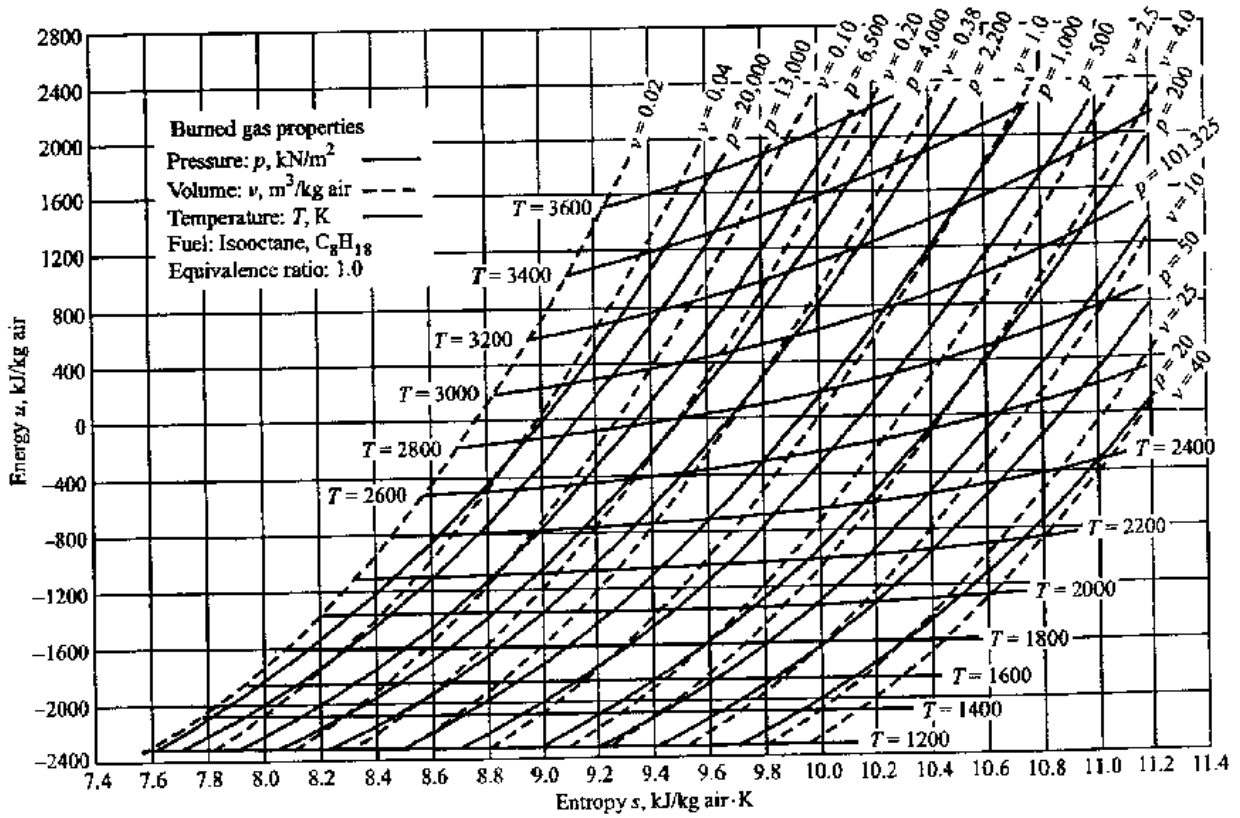

Source: Heywood, J.B.: *Internal Combustion Engine Fundamentals*, McGraw-Hill, New York 1988.

Figure 4.19 Internal energy versus entropy chart for equilibrium burned gas mixture, isooctane fuel, equivalence ratio 1.0.

USN

--	--	--	--	--	--	--	--	--	--

NEW SCHEME
------------

**Sixth Semester B.E. Degree Examination, July 2007**  
**Mechanical Engineering**  
**Internal Combustion Engines**

Time: 3 hrs.]

[Max. Marks:100

Note : Answer any FIVE full questions.

1.  a. What are combustion charts? Where these are used and why? (05 Marks)
- b. Derive an expression for change of internal energy and enthalpy during a process with variable specific heats. (05 Marks)
- c. The air-fuel ratio of a Diesel engine is 29:1. If the compression ratio is 16:1 and the temperature at the end of compression is 900 K, find at what cylinder volume the combustion is complete. Express this volume as percentage of stroke. Assume that the combustion begins at the top dead center and takes place at constant pressure. Take calorific value of the fuel as 42 MJ/kg,  $R = 0.287$  kJ/kgK and  $C_v = 0.709 + 0.00028T$  kJ/kgK. (10 Marks)
2.  a. Discuss the effect of the following parameters on the flame propagation of SI engines: i) A:F ratio ii) Compression ratio iii) RPM of the engine iv) Engine load v) Turbulence. (10 Marks)
- b. What are the factors that limits the compression ratio in Petrol engine? (04 Marks)
- c. Explain the difference between: i) Pre-ignition ii) Anti-ignition iii) Detonation. (06 Marks)
3.  a. Explain the effect of the following factors on delay period: i) Fuel properties ii) Intake temperature iii) Compression ratio iv) Engine speed v) Type of combustion chamber vi) Engine speed. (12 Marks)
- b. Explain briefly the phenomenon of "Diesel Knock". (04 Marks)
- c. What do you mean by Knock rating of Diesel fuel? (04 Marks)
4.  a. Draw neat layout of I and F head combustion chambers. Discuss their advantages and disadvantages. (10 Marks)
- b. What are the requirements of CI combustion chamber for Diesel engines? Explain why weak mixtures give better efficiency in CI engines. (10 Marks)
5. a. Explain the reasons for looking for alternate fuels for IC engines. (04 Marks)
- b. Explain alcohols as alternate fuels for IC engines bring out their merits and demerits. (06 Marks)
- c. With a neat sketch explain the working principle of a SU carburetor. (10 Marks)
6. a. How are injection systems classified? Describe them briefly. What are the limitations of air injection system? (10 Marks)
- b. Draw a typical heat balance sheet of IC engine. (05 Marks)
- c. Why over heating and over cooling of IC engines is harmful? (05 Marks)
7. a. Explain with neat sketches various types super charging arrangements. (10 Marks)
- b. Explain stratified charge engines and give their classification. (06 Marks)
- c. State the advantages and disadvantages of stratified charge engines. (04 Marks)
8. Write short notes on the following:
  - Sources of pollutants from IC engines
  - Effects of engine emissions on human health
  - Thermal reactor package
  - SI engine emission control. (20 Marks)

\*\*\*\*\*

Page No... 1

ME667

USN 

--	--	--	--	--	--	--	--	--	--

**NEW SCHEME****Sixth Semester B.E. Degree Examination, Dec. 06 / Jan. 07  
Mechanical Engineering  
Internal Combustion Engines**

Time: 3 hrs.]

[Max. Marks:100

**Note : Answer any FIVE full questions.**

1. ~~a.~~ Explain with the help of a p.v. diagram, the loss due to variation of specific heats in an Otto cycle. (08 Marks)  
~~b.~~ An engine working on the Otto cycle having compression ratio 7, uses hexane ( $C_6H_{14}$ ) as the fuel. The calorific value of fuel is 44000 kJ/kg. The air fuel ratio of the mixture is 13.67:1. Determine i) The percentage molecular change ii) Pressure and temperature at the end of combustion with and without considering the molecular change. Assume  $C_v = 0.712$  kJ/kgK, compression follows the law  $pv^{1.3} = C$ . The pressure and temperature of the mixture at the beginning of compression are 1 bar and  $67^\circ C$  respectively. (12 Marks)
2. ~~a.~~ Explain the effect of the following engine variables on flame propagation :  
 i) Fuel-air ratio  
 ii) Compression ratio  
 iii) Turbulence  
 iv) Engine load (08 Marks)  
~~b.~~ Explain the phenomenon of knocking in SI engine. (08 Marks)  
~~c.~~ Explain the effect of the following factors on knock in SI engine :  
 i) Compression ratio  
 ii) Super charging  
 iii) Turbulence  
 iv) Octane rating of fuel. (04 Marks)
3. ~~a.~~ With a suitable p-v diagram explain the stages of combustion in CI engine. (08 Marks)  
~~b.~~ Explain the effect of following factors on the delay period :  
 i) Engine speed  
 ii) Engine output  
 iii) Compression ratio  
 iv) Injection timing (08 Marks)  
~~c.~~ Explain the following :  
 i) Cetane number  
 ii) Diesel index. (04 Marks)
4. ~~a.~~ What are the basic requirements of a good SI engine combustion chamber? Explain them. (08 Marks)  
~~b.~~ Sketch and explain the side valve (L-Head) combustion chamber. (04 Marks)  
~~c.~~ What is Indirect Injection Type (IDT) combustion chamber? With a suitable sketch explain Ricardo Swirl combustion chamber. (08 Marks)

Contd.... 2

- 5 a. Give the general chemical formula of the following constituents of crude petroleum.  
i) Paraffin  
ii) Napthane  
iii) Olefin  
iv) Aromatic series  
Also give their molecular arrangements and mention whether they are saturated or unsaturated. (12 Marks)
- b. With a neat sketch explain the working principle of a simple carburetor. (08 Marks)
- 6 a. What are the functional requirements of an injection system? With a neat sketch explain the single cylinder Jerk pump fuel injection system. (12 Marks)
- b. Explain the necessity of engine cooling. (06 Marks)
- c. List any two advantages of liquid cooling system. (02 Marks)
- 7 a. What is supercharging? How is it achieved? (04 Marks)
- b. What is a stratified charge engine? Describe with sketch Broderson method of charge stratification. (08 Marks)
- c. With a suitable sketch explain the working of a Wankel rotary combustion engine. (08 Marks)
- 8 a. Explain the mechanism of formation of CO and NO<sub>x</sub> in petrol engines. (06 Marks)
- b. Describe the EGR (Exhaust Gas Recirculation) device for the control of NO<sub>x</sub>. (08 Marks)
- c. With a suitable sketch explain the catalytic converter. (06 Marks)

Page No... 1

ME667

USN

--	--	--	--	--	--	--	--	--	--

<b>NEW SCHEME</b>
-------------------

Sixth Semester B.E. Degree Examination, July 2006

Mechanical Engineering

Internal Combustion Engines

Time: 3 hrs.]

[Max. Marks:100

Note: 1. Answer any FIVE full questions.

1.  a. Compare air cycle, fuel-air cycle and actual cycle of SI engine on the basis of operations and working media. (06 Marks)
- b. The combustion in a diesel engine is assumed to begin at IDC and to be at constant pressure. The A/F ratio is 28:1, the calorific value of the fuel is 42 MJ/kg and the specific heat of products of combustion is given by :  
 $C_v = 0.71 + 20 \times 10^{-5} T$  kJ/kg K, where T is in K.  
 $R$  for the products = 0.287 kJ/kgK  
 If the compression ratio is 14:1 and the temperature at the end of compression is 800K, find at what percentage of the stroke combustion is completed. (10 Marks)
- c. Explain briefly the effect of dissociation on power. (04 Marks)
2.  a. Discuss briefly the stages of combustion in SI engines with the help of pressure-crank angle diagram. (08 Marks)
- b. List and explain briefly the engine variables that will have influence on the flame propagation. (06 Marks)
- c. Explain with neat sketches knocking in SI engines. (06 Marks)
3.  a. How does the combustion phenomenon in CI engines differ from that of SI engines? Briefly explain. (04 Marks)
- b. Explain briefly the stages of combustion in CI engines. (08 Marks)
- c. List and explain briefly the effect of various factors on delay period in CI engines. (08 Marks)
4.  a. What are the basic requirements and the objectives of good combustion chamber design? (05 Marks)
- b. Explain briefly : (06 Marks)
  - i) Induction swirl
  - ii) Squish and tumble
  - iii) Turbulence
- c. With neat sketches briefly explain : (09 Marks)
  - i) Ricardo's turbulence head combustion chamber.
  - ii) Divided combustion chamber.
  - iii) M-type combustion chamber.

Cond.... 2

- 5 a. Explain briefly the mixture requirements for an SI engine. (04 Marks)  
b. What are the limitations of the simple carburetor? How are they overcome by incorporating compensating devices? (08 Marks)  
c. Determine the sizes of fuel orifice to give a 13.5 : 1 air-fuel ratio, if the venturi throat has 3cm diameter and the pressure drop in the venturi is 6.5cm Hg. The air temperature and pressure at carburetor entrance are 1 bar and 27°C respectively. The fuel orifice is at the same level as that of the float chamber. Take density of gasoline as 740 kg/m<sup>3</sup> and discharge coefficient as unity. Assume atmospheric pressure to be 76cm of Hg. (08 Marks)
- 6 a. Explain briefly :  
i) Air injection.  
ii) Airless injection methods used in CI engines. (06 Marks)  
b. What are the merits and limitations of petrol injection? (06 Marks)  
c. Discuss briefly the methods of cooling used in internal combustion engines giving their advantages and disadvantages. (08 Marks)
- 7 a. What are the advantages and disadvantages of stratified charge engines? (06 Marks)  
b. What are the requirements of a multi-fuel engine? List the difficulties associated with multi-fuel operation. (06 Marks)  
c. Briefly explain the working of Wankel rotary combustion engine. (08 Marks)
- 8 Write short notes on any four of the following :  
a. Catalytic converter package.  
b. Cold starting of CI engines.  
c. Compressed natural gas.  
d. Electronic fuel injection.  
e. Emission control in automobiles.  
f. Water injection. (20 Marks)

\*\*\*\*\*

<b>NEW SCHEME</b>
-------------------

ME667

Reg. No. 

--	--	--	--	--	--	--	--	--	--

**Sixth Semester B.E. Degree Examination, January/February 2006**  
**Mechanical Engineering**  
**Internal Combustion Engines**

Time: 3 hrs.)

(Max.Marks : 100)

**Note:** Answer any FIVE full questions.

1. (a) Why actual cycles differ from the ideal cycles? List out the reasons. (8 Marks)  
 (b) Explain the effect of variable specific heat on Otto cycle on a P-V diagram. (6 Marks)  
 (c) What are combustion charts? Explain. (6 Marks)
2. (a) Describe briefly the various stages of combustion in spark ignition engines with help of P-θ diagram. (8 Marks)  
 (b) What is detonation? Explain any two effects of detonation. (8 Marks)  
 (c) How are S.I. engine fuels rated? Explain. (4 Marks)
3. (a) What is Ignition delay or ignition lag? Name and describe the two components of ignition delay period. (10 Marks)  
 (b) What is diesel knock? Explain the methods of controlling diesel knock. (10 Marks)
4. (a) What are the basic requirements of a good combustion chamber for spark ignition engines? (10 Marks)  
 (b) Explain with a diagram M-combustion chamber. List its advantages. (10 Marks)
5. (a) Briefly explain the chemical structure of petroleum. (5 Marks)  
 (b) Discuss briefly alcohols as diesel engine fuels. (5 Marks)  
 (c) Explain with a neat sketch, the working of a simple carburettor. (10 Marks)
6. (a) With a schematic diagram explain the working of Jecck pump injection system. (10 Marks)  
 (b) Explain with a neat sketch thermostat controlled cooling system. (10 Marks)
7. (a) What is supercharging? What are its objectives? (4 Marks)  
 (b) Explain the supercharging of S.I. engines. (8 Marks)  
 (c) What is stratified charge engine? What are its advantages and disadvantages? (8 Marks)
8. (a) What are the main pollutants emitted by petrol engine? Explain. (8 Marks)  
 (b) Define total emission control package. Explain with a neat sketch, the working principle of thermal reactor package. (12 Marks)

\* \* \* \*

Page No... 1

NEW SCHEME

ME667

USN

--	--	--	--	--	--	--	--	--	--

**Sixth Semester B.E. Degree Examination, July/August 2005**  
**Mechanical Engineering**  
**Internal Combustion Engines**

Time: 3 hrs.]

[Max.Marks : 100

**Note: Answer any FIVE full questions.**

1. (a) Explain the different factors that affect the deviation of actual cycles from theoretical cycles. (5 Marks)
- (b) Explain briefly the combustion chart. (5 Marks)
- (c) A petrol engine having a compression ratio 6, uses a fuel with a calorific value of  $42\text{ MJ/kg}$ . The air fuel ratio is 15:1. Pressure and temperature at the start of the suction stroke is 1 bar and  $57^\circ\text{C}$  respectively. Determine the maximum pressure in the cylinder if the index of compression is 1.3, and the specific heat at constant volume is given by  $C_v = 0.678 + 0.00013T$ , where T is in kelvin. Compare this value when  $C_v = 0.717\text{ kJ/k}$  (5 Marks)
2. (a) Explain the three different stages in SI engine combustion. (3 Marks)
- (b) Briefly explain the effect of various engine operating variables on SI engine knocking. (3 Marks)
- (c) Explain briefly HUCR and octane No. (4 Marks)
3. (a) Describe the requirements of SI engine combustion chamber. (4 Marks)
- (b) Explain with a neat sketch, F lead and I lead combustion chamber. (10 Marks)
- (c) Explain the role of swirl in diesel engines. (6 Marks)
4. (a) Briefly explain the alternative fuels for diesel engines. (8 Marks)
- (b) Explain with a neat sketch M type combustion chamber. (10 Marks)
- (c) Explain the influence of chemical structure on knocking in diesel engines. (4 Marks)
5. (a) Briefly explain the mixture requirements for S.I. engine. (6 Marks)
- (b) What are the limitations of the simple carburetor. (4 Marks)
- (c) Explain with a neat sketch working of a constant vacuum carburetor. (10 Marks)
6. (a) Explain with a neat sketch jerk pump injection system. (12 Marks)
- (b) Explain with a neat sketch the multi point fuel injection system (port injection). (8 Marks)
7. (a) Describe the air cooling system and compare it with other cooling systems. (8 Marks)
- (b) With a neat sketch describe the forced water cooling system of an automobile duly bringing out the role played by the thermostat and radiator. (12 Marks)

Contd.... 2



Page No... 2

**ME667**

8. Write short notes on any FOUR of the following :

- a) Super charging of IC engines
- b) Stratified charge engines
- c) Rotary piston engines
- d) Emission control in automobiles
- e) Water injection
- f) Catalytic converters.

(20 Marks)

\*\*\* \*\*